

MODULITH® SLX-F2
THE LITHOTRIPTER

STORZ MEDICAL

Our philosophy:
humane technology – technology for people

Rather than expecting people to adapt to new technologies, we must ensure that technical progress is adapted to the requirements of people.

Our goal: better therapies through new technologies. Established in 1987, STORZ MEDICAL AG is a Swiss member company of the KARL STORZ Group. The objective pursued by our physicists and engineers is to continuously improve shock wave technology and to develop new system concepts.

Our products have proved their efficacy in millions of cases in the field of urology.

Man is the measure of all things (Protagoras)

Our history: innovation in the service of people

- **The shock wave system, the heart of the lithotripter:** STORZ MEDICAL is the only manufacturer worldwide to have developed its own shock wave generator. Today, the cylindrical source forms an integral part of any STORZ MEDICAL shock wave system and has proved an extraordinary success. Measurements carried out on the STORZ cylindrical source by independent scientific institutions confirm its outstanding stone disintegration efficiency and optimum values in terms of all relevant medical parameters such as pressure, energy flux density, repetition accuracy and minimized skin impact.
- **In-line stone localization provides maximum reliability:** high-precision localization and focusing of the target area can only be accomplished with a co-axial arrangement of the shock wave generator and localization system. STORZ MEDICAL is the only manufacturer of shock wave systems to have developed an in-line ultrasound and/or X-ray localization method designed for localization in the usual vertical (AP) direction.

Every new lithotripter launched by STORZ MEDICAL is bound to set new standards in the market. Even in areas in which we have established ourselves as the unchallenged market leader, we do not sit back and rest on our laurels, but rather provide additional technical innovations to further increase therapy efficiency and make therapies even gentler on patients.

The next step in innovation:

- **Dual Focus – shock waves tailored to specific requirements:** for the first time in the history of lithotripsy, it is possible to adapt the focus size of the lithotripter to specific anatomical conditions. A larger or smaller focus can be selected depending on the indications to be treated. The shock wave field can thus be adjusted to various stone sizes and positions to optimize therapy results.



Dual Focus

The benefits of a small focus

During lithotripsy treatment, the forces transmitted by the shock waves to the calculus exceed the limits of elasticity of the stone material, thus causing the stone to be fragmented into tiny sand-like fragments. Depending on the type and consistency of the stone to be broken up, high forces may be required to ensure reliable stone fragmentation. Although extracorporeally induced lithotripsy is generally free from any serious side effects, tissue injury in the focal zone cannot be completely avoided. In order to minimize tissue damage in the regions surrounding the focal zone, the focal zone should be confined to the stone as such. However, the shock wave energy in the focus should still be high enough to ensure efficient fragmentation even of hard and impacted stones. Featuring a small focal zone with narrow pressure field, the long-proven STORZ MEDICAL cylindrical source provides the perfect solution to meet these requirements. In physical terms, a small focus is conditional upon a large aperture of the shock wave source (diameter 30 cm). Owing to technical limitations, many shock wave generators using different methods for shock wave generation are not able to produce precise focal zones in an optimum manner.

The benefits of a large focus

In clinical routine, precise stone positioning in the therapy focus is often not possible. Unlike with ureter stones, respiration-induced movements of the kidney, for example, cause renal stones to shift out of the focal zone at regular intervals. Broken off concretions can thus move away from the stone into the renal pelvis or other calyces so that they can no longer be localized together with the main target concrement if a small focus is used.

Dual Focus – the choice is yours!



With a simple press of a button you can change between a small focus and a large focus or vice versa – even during the therapy session. In this way, you are free to select the treatment strategy best suited to the patient's specific indication and anatomical conditions. A ground-breaking solution in the history of lithotripsy.

Dual Focus

No two stones or anatomies are the same. Hence, different focal zones are required to accommodate for specific stone sizes and positions. Higher pressures and good energy concentration are necessary for the disintegration of impacted ureter stones, whereas

lower pressures and a wider focal zone can be used in the treatment of large stones located in the renal pelvis. The Dual Focus of the MODULITH® SLX-F2 enables you to adapt shock wave parameters to specific indications in an optimum manner and to develop your own treatment strategies. To underline this decisive new system feature, „F2“ has been appended to the name of the MODULITH® SLX.

Left:
Precise focus for
ureter stones

Right:
Extended focus for
kidney stones

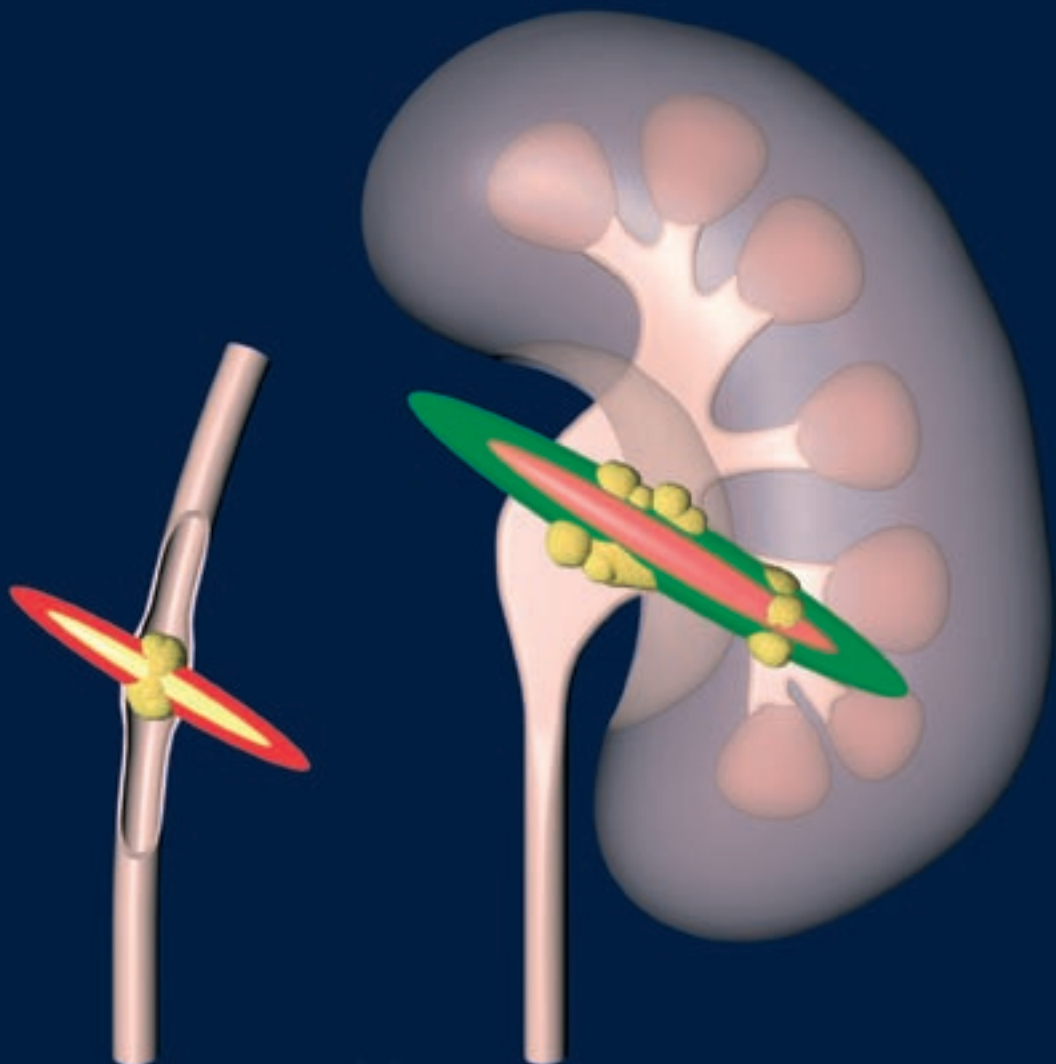

MODULITH® SLX-F2

6





Innovation and experience

The lithotripter MODULITH® SLX-F2 is the result of over 20 years of experience in the design of lithotripters and of millions of successful lithotripsy treatments performed. Characteristic features include ergonomic patient positioning, easy accessibility and, above all, easy and reliable localization.

These are essential requirements to ensure that the excellent stone disintegration quality of the MODULITH® SLX-F2 goes hand in hand with outstanding therapy efficiency.

Yet, the MODULITH® SLX-F2 is more than just a lithotripter. With high-quality integral X-ray and ultrasound components, it can be used as a diagnostic and therapeutic workstation. The many different patient positioning options and the Trendelenburg tilt feature (0-15° head-down tilt) speak for themselves.



The lithotripter concept of the MODULITH® SLX-F2

Easy patient positioning

When positioning immobile patients, doctors and nursing staff are required to use extreme caution and care. Likewise, helping sedated patients to get on or off the patient table is a situation that is often critical and difficult to handle. Again, STORZ MEDICAL has underscored its commitment to innovation to improve the ergonomic design of its systems and increase patient safety. The patient table of the MODULITH® SLX-F2 is equipped with a tilting device with a 30° swivelling angle to help patients sit up on the patient table or lie down horizontally for treatment, thus making patients feel safer and easing the physical strain on the personnel.

8



Multifunctionality



Multifunctionality

The MODULITH® SLX-F2 is not only a one-of-a-kind lithotripter, but also a highly versatile, multifunctional workstation. The manifold patient positioning options provided by the patient table allow the most varied urological examinations and endourological treatments to be performed. Access to the patient is possible from three sides.

If anaesthesia is required, for example, easy access to the patient's head is necessary for intubation. When treating short patients, the table extension on the head side of the patient table can be removed easily and effortlessly.



Ergonomic design for optimal handling in the daily routine

In the development of the MODULITH® SLX-F2, we have given special attention to an ergonomic design and the requirements of the daily routine. Fundamental design objectives included easy access to patients from three sides, especially in the head area, and an innovative operator system to relieve users of many routine tasks and enable them to concentrate on the essentials.

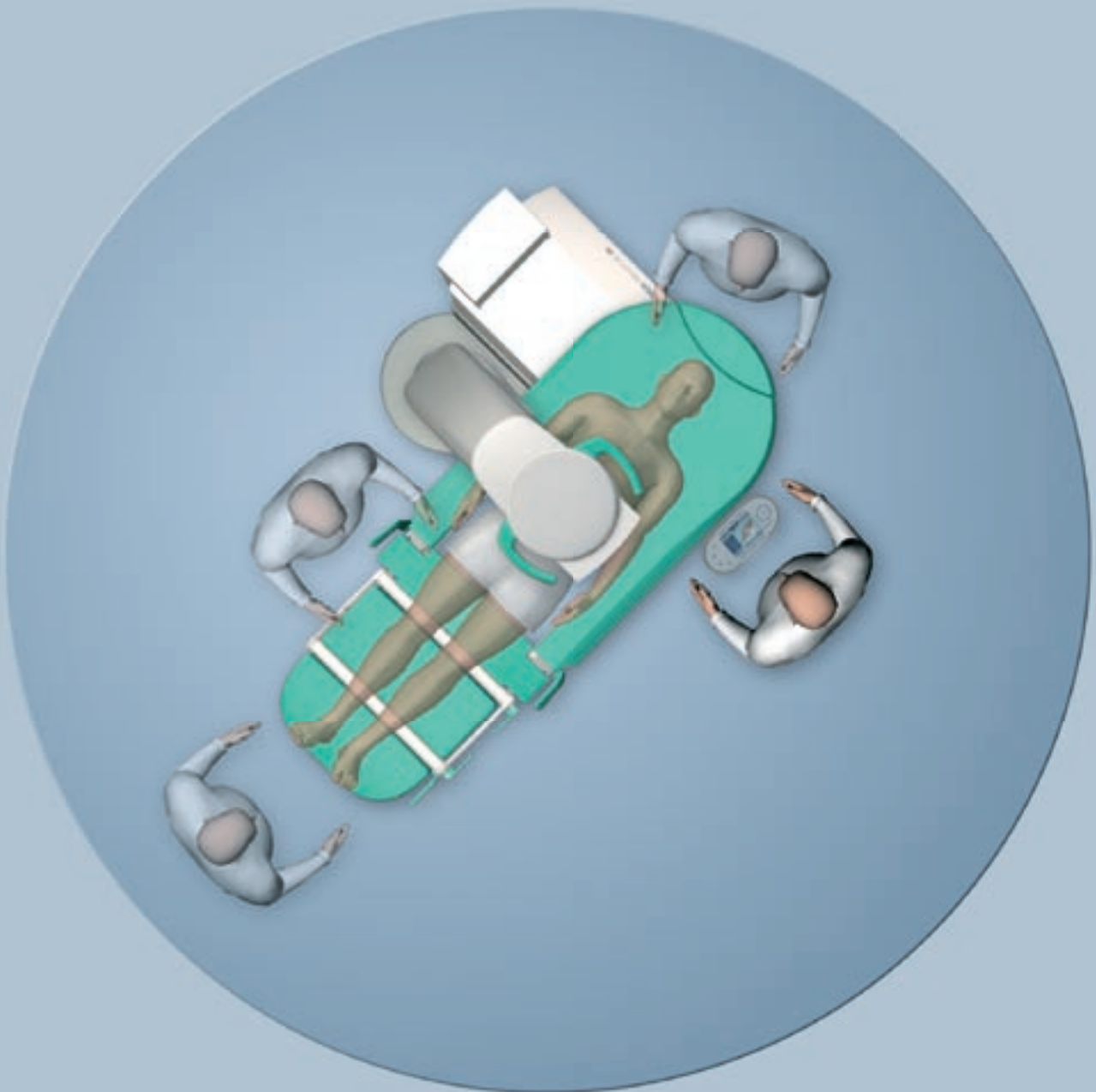

The lithotripter concept of the MODULITH® SLX-F2

No patient repositioning required

The central arrangement of the therapy source in the vertical (AP) direction adds to the highly ergonomic and user-friendly design of the MODULITH® SLX-F2. No patient repositioning is required. The left or right kidney/ureter can be treated independently of the patient's alignment.

This means that the patient's head is always in the same position and that monitoring of vital parameters is greatly facilitated. This is of crucial importance in the rare cases in which anaesthesia is required.

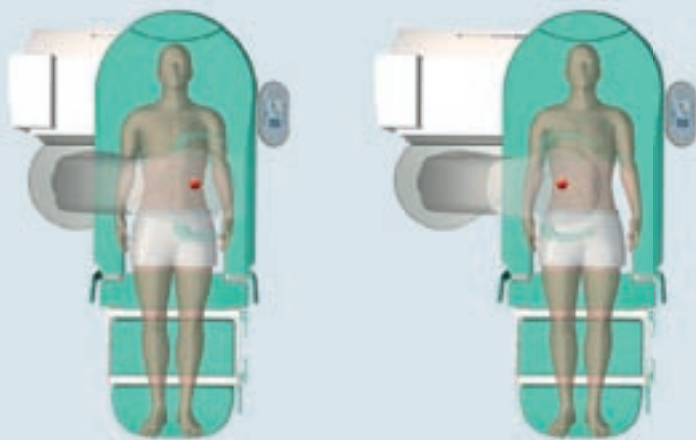

The MODULITH® SLX-F2 can be equipped with mobile C-arcs from various manufacturers or with an integral X-ray system developed by STORZ MEDICAL. The patient table is radiolucent over the entire abdominal region so that unlimited visualization of the urogenital tract is possible from the upper pole of the kidney to the bladder. During this process, the shock wave source is swivelled into parking position to remove it from the X-ray path.

Fluoroscopic projections and localization in the commonly used vertical (AP) direction is based on the known standards of urological diagnostics to ensure clear orientation in the usual form.

Ultrasound examinations can be performed by means of various ultrasound systems. Even in-line ultrasound devices, which are integrated into the therapy head, can be used.

Trendelenburg tilt

11

Certain transurethral examinations or anaesthetic procedures are facilitated if the patient is in a head-down position. The continuously adjustable Trendelenburg tilt ensures optimal treatment conditions even in difficult circumstances.



Cylindrical source

The therapy source is the core component of any lithotripter. It not only determines the stone disintegration efficiency but also the localization systems that can be integrated into the lithotripter.

Shock waves are extremely short pressure pulses with peak pressures between approx. 10 to over 100 MPa. This is equivalent to 100 to 1000 times the atmospheric pressure (100

to over 1000 bar). Originally, high-energy underwater sparks were used that lead to an explosive evaporation of water, thus producing short intense pressure disturbances in the surrounding water bath (electrohydraulic principle). The energy thus generated was focused and introduced into the patient's body, and applied to the stone for fragmentation.

Despite its uncontested efficiency, the electrohydraulic method has several disadvantages, which caused STORZ MEDICAL to develop alternative shock wave generation systems as early as in 1988.

Factors requiring improvement

- **Accuracy:** similarly to a lightning stroke, the spark gap of electrohydraulic systems cannot be predicted with any acceptable level of accuracy. This results in an uncontrolled shift of the focal zone by several millimetres. Hence, precise application down to the last millimetre is not possible.
- **Service life:** the spark gap causes severe consumption of the electrodes, requiring early electrode replacement after one or several treatment sessions. This not only involves interruptions to the operation of the lithotripter but also increases costs of consumables.
- **Energy dosing:** gradual electrode consumption has an uncontrolled effect on the amount of energy applied with each pressure pulse. Such energy fluctuations cause irregular treatment.
- **Elimination of unfocused shock wave:** a portion of the primary shock wave enters the patient's body in the form of an unfocused wave which strikes sensitive organs such as the lungs, heart etc. Consequently, electrohydraulic systems lead to an increased number of extrasystoles and thus generally require ECG-based shock wave triggering.
- **Noise:** apart from generating the actual shock waves, electrohydraulic systems also produce strong audible sound waves which increase the noise level without having any positive effect on the stone fragmentation efficiency. In many cases, ear protection is required.

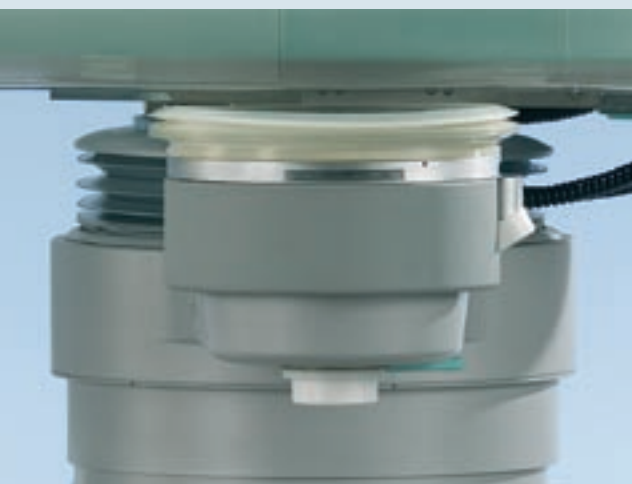

Unique shock wave generator

With its patented cylindrical source, STORZ MEDICAL is the only manufacturer worldwide to have developed its own shock wave generator for exclusive use in all STORZ MEDICAL shock wave systems.

Cylinder geometry – the key to success

The specific geometry of the cylindrical shock wave source developed by STORZ MEDICAL has allowed to eliminate the drawbacks of spark gap systems and to decisively improve electromagnetic shock wave generation methods. Electromagnetically generated shock waves provide excellent dosing capability and can be triggered without any significant fluctuations at low energy levels and high pressures. One of the most crucial medical requirements is thus already satisfied, which means that the pain produced by shock waves and the need for anaesthesia can be controlled in an optimum manner. The use of large-sized reflectors with ex-

tremely large diameters of 30 cm allows the shock wave energy at the skin entry point to be distributed over a large surface area to substantially reduce any discomfort. Moreover, the cylindrical source is also designed for an exceptional penetration depth of up to 16.5 cm. Even in obese patients, shock waves can thus be reliably focused on almost any stone to ensure effective fragmentation.

Lithotripsy is also effective in obese patients

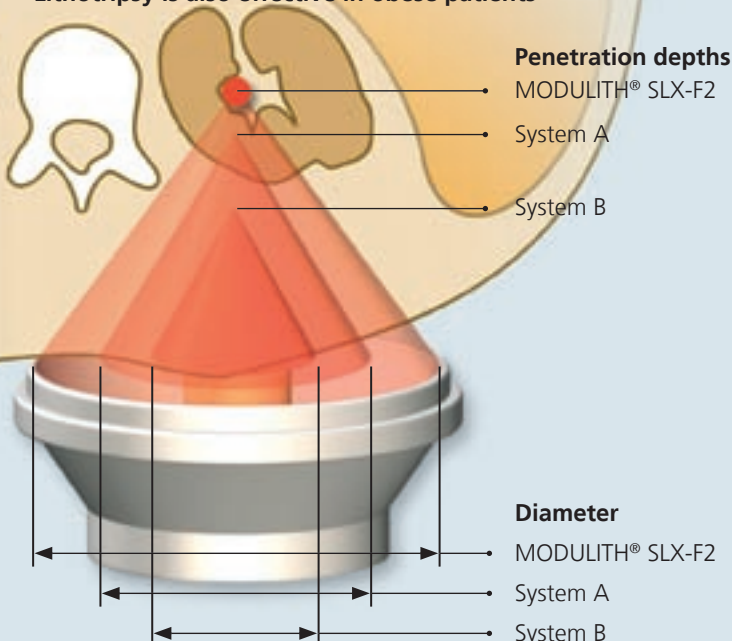

The STORZ MEDICAL cylindrical source provides excellent values for all major parameters:

- high fragmentation efficiency*
- minimum side effects
- large penetration depth for obese patients
- constant energy emission
- good dosing capability
- long service life
- low operating costs

*J. M. H. Teichman, A. J. Portis, P. P. Cecconi, W. L. Bub, R. C. Endicott, B. Denes, M. S. Pearle and R. V. Clayman: In vitro comparison of shock wave lithotripsy machines; The Journal of Urology, Vol. 164, 1259-1264, October 2000

X-ray localization

MX X-ray system for localization and diagnostics

Three-dimensional stone localization requires fluoroscopic projections to be performed in two directions, i.e. at 0° and 30° relative to the vertical. Most lithotripters use X-ray systems that are swivelled in cranio-caudal direction as this solution is technically less complex than the lateral (orbital) swivel. However, AP and lateral projections provide better image

quality than cranio-caudal projections and ensure easy and reliable identification of the stone depth.

STORZ MEDICAL has developed an isocentric mechanism for lateral swivel to ensure continuous fluoroscopy during movement. The target area can thus be reliably controlled while the X-ray system is moved to change between AP and lateral projection. Positioning errors can thus be avoided.

14



PA/AP projection



The benefits of lateral projections over cranio-caudal projections for stone localization

There are two decisive reasons why kidney stones should be localized by means of lateral projections:

1. Respiration-induced movements of the kidney and the stone to be disintegrated mostly occur along the body's longitudinal axis, i.e. in cranio-caudal direction. Precise positioning of the kidney stone in the therapy focus in the third dimension requires 30° projections. Owing to respiration-induced movements, this method inevitably leads to localization errors which can be eliminated almost entirely when performing lateral projections.
2. When projections are made in cranio-caudal direction, the fluoroscopic distance in the human tissue is several centimetres longer than with lateral projections. This increases exposure to radiation both for doctors and for patients and reduces the image quality.



30° lateral projection

Airbags provide free view

The therapy source can be completely removed from the X-ray path to ensure an unhindered view of the therapy field during X-ray fluoroscopy.

Owing to the patented geometry of the STORZ MEDICAL cylindrical shock wave source, direct (in-line) monitoring of the therapy field through the cylindrical source is also possible while the source is coupled to the patient's body. The water cushion required for shock wave transmission and application interferes with the transmission of the X-rays due to scattering and absorption.

In order to eliminate these effects, airbags are used which force the water located between the shock wave source and the patient out of the X-ray path during X-ray fluoroscopy. High-contrast fluoroscopic images can thus be produced even with the therapy source remaining coupled to the patient's body. A second airbag is available for 30° lateral projections.

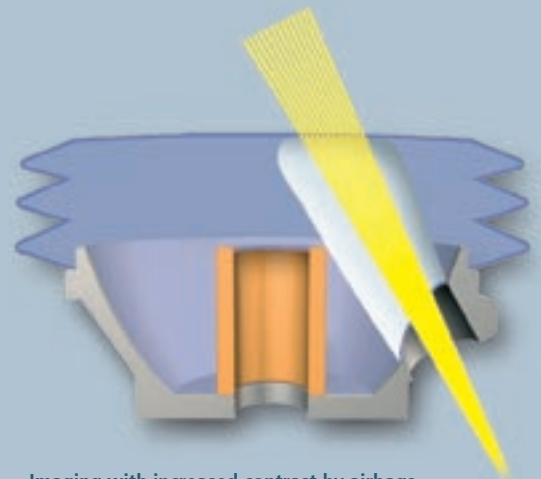
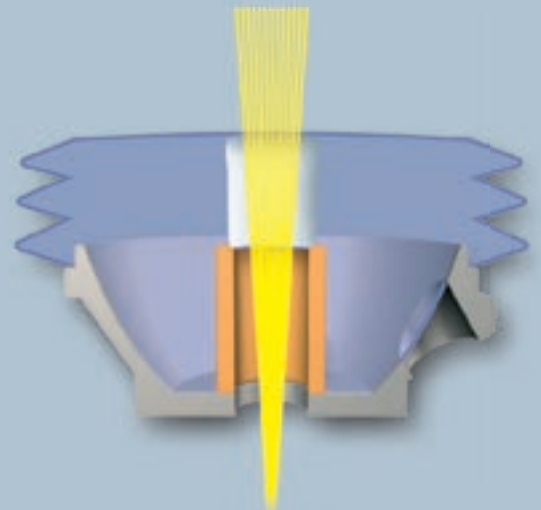
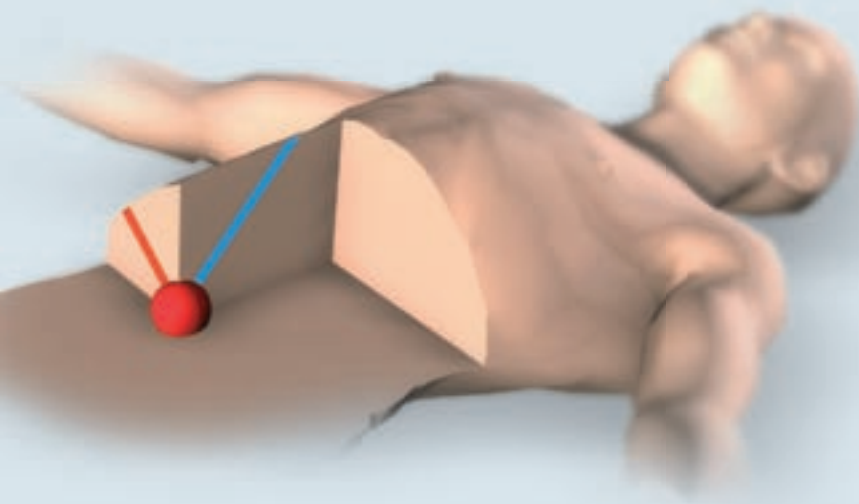

Imaging with increased contrast by airbags

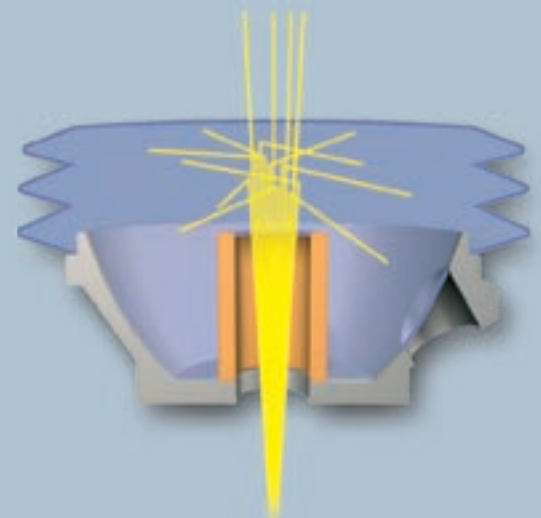

Reduced contrast by scatter radiation without airbags

In-line ultrasound localization

Ultrasound localization concept

Stone localization can be performed by means of sonography whenever the patient's specific anatomical conditions allow reliable visual stone identification. This requirement is generally fulfilled in the case of kidney stones. If ultrasound waves are used for localization and treatment control, the position of the stone can be continuously monitored without

exposure to radiation. This may prove beneficial in the presence of strong respiration-induced movements or in restless patients. The cylindrical design of the STORZ MEDICAL therapy source allows the ultrasound transducer to be installed in the centre of the therapy head so that the ultrasound image shows the stone on the central therapy head axis.

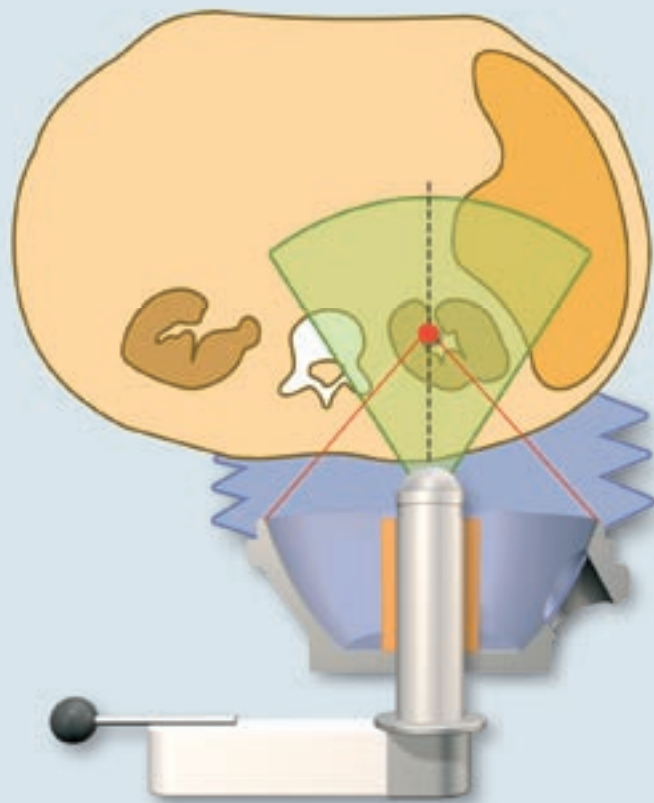

This in-line arrangement ensures that obstacles such as ribs or the iliac bone are directly visible in the ultrasound image. Moreover, sensitive regions such as the lungs, heart or gas-filled organs can be reliably identified and by-passed during shock wave application. This allows even children to be treated with maximum care and without any significant risks.

In-line localization for maximum precision

On their way from the skin surface to the stone, shock waves and ultrasound waves slightly deviate from the linear direction of propagation due to the effects of refraction at the boundary layers between neighbouring tissues. However, the co-axial (in-line) arrangement of the diagnostic ultrasound transducer and therapeutic shock wave source ensures that shock waves and ultrasound waves pass through the same tissue regions so that only minimum deviations occur with respect to their directions of propagation. This ensures optimum correspondence between the localized target area position and the shock wave focus.

In order to determine the depth of the stone to be fragmented, a precise measurement of the propagation time of the ultrasound signal is necessary. As the specific properties of tissues such as skin, fat, muscle tissue or kidney tissue are different in each patient, minor deviations in the stone depth measurements cannot be avoided. If the in-line system arrangement is used, these deviations are limited to the linear extension of the cigar-shaped focus.

This ensures maximum targeting accuracy and fragmentation efficiency. Minor deviations in the focus depth are insignificant, and lateral shifts beyond the focal area caused by respiration-induced movements, for example, are immediately visible in the ultrasound image and can be corrected on-line.

Dual imaging

The combination of X-ray and ultrasound localization allows the physician to select at his/her own discretion the localization method best suited to a specific application. Simultaneous use of both localization methods is also possible. The in-line ultrasound image shows whether the calculus is still located in the focus and indicates disintegration progress. Unparalleled reliability and precision during localization and treatment are thus guaranteed.

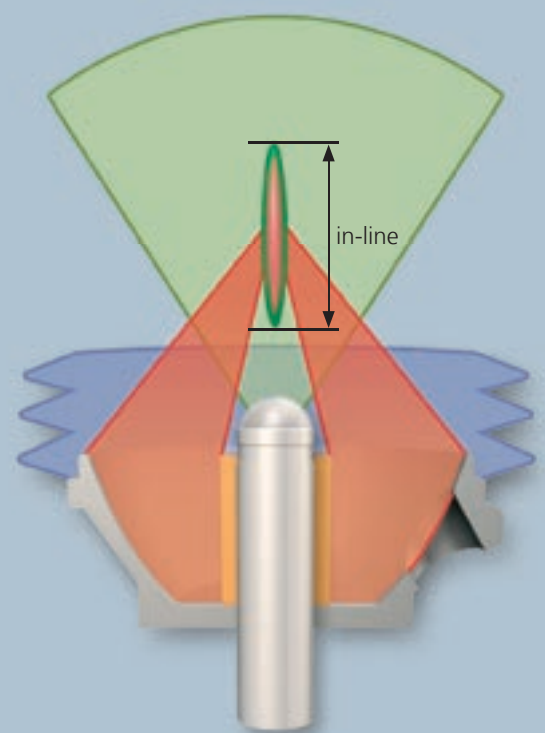

Localization tolerance

Networking capability

A high degree of network connectivity and automation is an essential requirement for modern hospitals to operate efficiently. The MODULITH® SLX-F2 is designed for easy integration into existing hospital networks.

PACS DICOM HIS/RIS integration

Digital archiving of medical images and patient information is becoming increasingly important to ensure effective quality assurance.

The MODULITH® SLX-F2 is, of course, designed to provide a full range of DICOM 3 compliant image archiving options and can be connected to DICOM 3 compatible imagesetters. Patient data can be retrieved from the hospital information system (HIS) or radiology information system (RIS) via the DICOM worklist modality.

STORZ MEDICAL lithotripsy database (optional)

This software package is specifically tailored for lithotripsy treatments. It is designed for the recording and statistical evaluation of the shock wave therapy, including anamnesis, stone identification, diagnosis/analysis, follow-up, image integration and preparation of reports for patients' attending physicians.

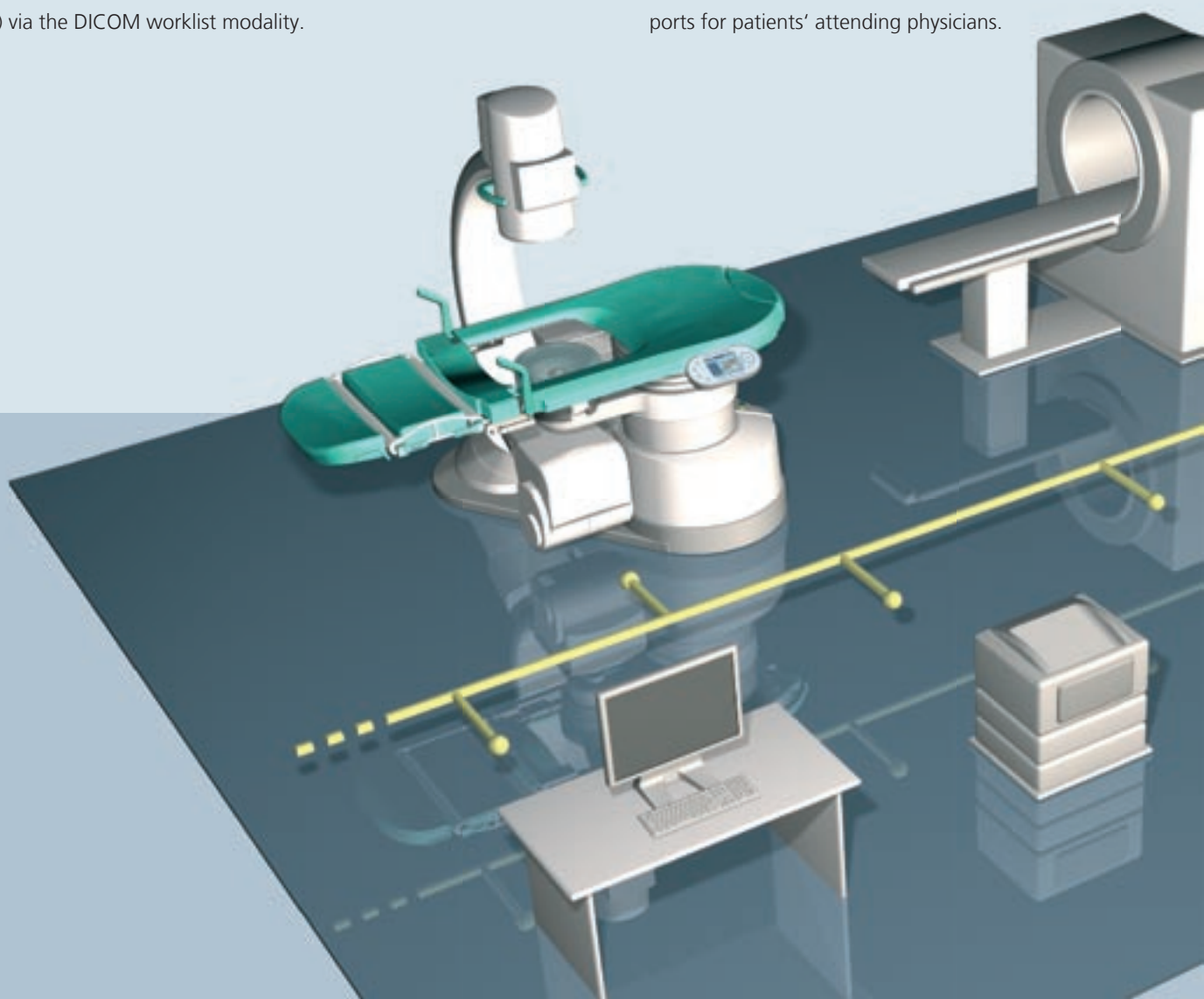

Digital platform – open for the future

Owing to its modular design, the MODULITH® SLX-F2 is well prepared to accommodate a variety of software and hardware options. It features a unique control and communication platform to ensure easy integration into existing structures and improved workflow efficacy.

SCB (Storz Communication Bus) compatible

With its Storz Communication Bus (SCB), KARL STORZ GmbH + Co. KG has set new standards in the control of medical equipment for operating theatres. The SCB is part of the future-oriented OR1 concept. All networked systems such as light sources, endoscopy devices, operating theatre lamps etc. can be centrally controlled via a touch screen.

The MODULITH® SLX-F2 can be adapted to this concept to form part of an interventional workstation. This also allows remote control of the lithotripter and imaging systems to be optimized.

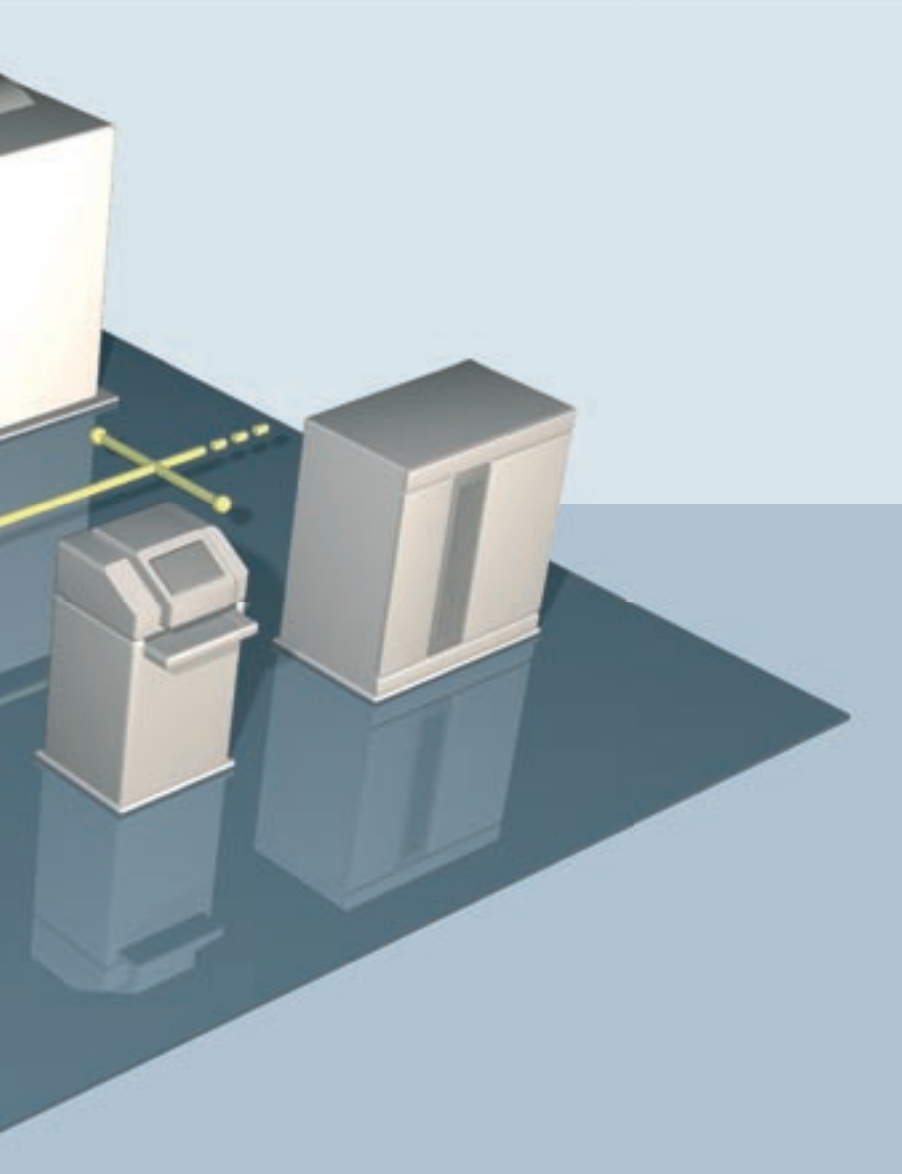

Automatic positioning (optional)

The stone can be identified on the screen by using your fingertip. The system automatically moves the stone into the shock wave focus.



Lithotripsy database

Extension capability and modular design



20



Modular design principle

In the development of the MODULITH® SLX-F2, STORZ MEDICAL has maintained the proven modular design principle. Similar to a building block system, various localization and accessory units can be combined according to the customer's specific needs. This solution provides maximum flexibility as your workstation can be tailored to your individual requirements. Individual components can be upgraded for years to come to accommodate the latest technical developments. In many cases, X-ray systems of predecessor models can, for example, be combined with the new MODULITH® SLX-F2 lithotripter to obtain an even more efficient unit.

Mobile lithotripsy



Flexibility

Apart from being available as a stationary system unit, the MODULITH® SLX-F2 is also offered as a mobile version to allow the lithotripter to be jointly used by several hospitals. The mobile version comes with an undercarriage to ensure easy transport.

21

C-arcs from various manufacturers can be connected with the lithotripter by means of an aiming device without reducing the localization accuracy. A fully operative lithotripsy workstation is thus ready for use in a few minutes.



Service – always by your side



- **Site planning**
- **Installation**
- **Application training**
- **Service training**
- **Exchange of experience among users**
- **Maintenance**
- **Hotline**
- **Repair**

The services offered by STORZ MEDICAL AG range from pre-installation consultation right up to prompt assistance during everyday operation.

22

Extensive user training and application support are, of course, included in the scope of supply. STORZ MEDICAL also organizes technical training sessions so that minor problems can be rectified immediately by hospital in-house technicians. The MODULITH® SLX-F2 is characterized by its excellent reliability. But should any faults be encountered, our worldwide service network ensures that qualified help is always near at hand.

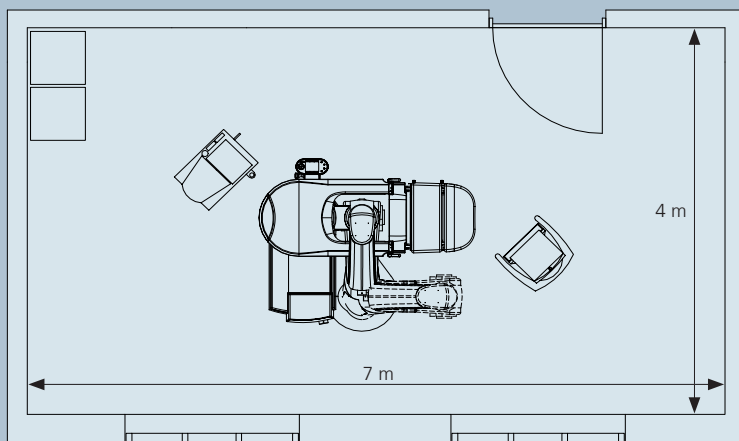

Site planning

Easy installation

Minimum room size 4 m x 5 m

Technical specifications

Stationary concept:	MODULITH® SLX-F2 (stationary): Dimensions (L x W x H): Weight of total system:	for stationary use with integrated X-ray system 216 cm x 187 cm x 202 cm 885 kg
Stationary & transportable concept:	MODULITH® SLX-F2 (transportable): Dimensions of lithotripter (L x W x H): Weight of lithotripter:	for stationary or transportable use with X-ray C-arm 169 cm x 89 cm x 124 cm 695 kg
Shock wave source:	Shock wave principle: Penetration depth: Shock wave focus:	electro-magnetic Dual Focus cylindrical source 0 - 165 mm Dual Focus, size selectable during treatment
Integrated X-ray system:	Localisation projections: X-ray generator: Imaging modes:	in-line AP/PA and 30° lateral (iso-centric) 50 kW (other generators optional) Fluoroscopy, Radiography and Digital Radiography
X-ray C-arm system:	Localisation projections: X-ray C-arm: Imaging modes:	in-line AP/PA and 30° lateral selected mobile X-ray C-arm systems Fluoroscopy and Digital Radiography
Ultrasound system:	Localization projection: Ultrasound System:	in-line localization B & W (colour Doppler unit optional)
Treatment table:	Applications: Table movements:	Lithotripsy, Endourology and urological diagnostics motorized X–Y–Z and Trendelenburg

HUMANE TECHNOLOGY - TECHNOLOGY FOR PEOPLE



STORZ MEDICAL

STORZ MEDICAL AG · UNTERSEESTRASSE 47 · CH-8280 KREUZLINGEN
TEL. +41 (0)71 677 45 45 · FAX +41 (0)71 677 45 05
E-MAIL INFO@STORZMEDICAL.COM · WWW.STORZMEDICAL.COM